

SILL

49

Das Lichtwerkzeug
für Architektur und Städtebau

The light tool
for architecture and urban planning

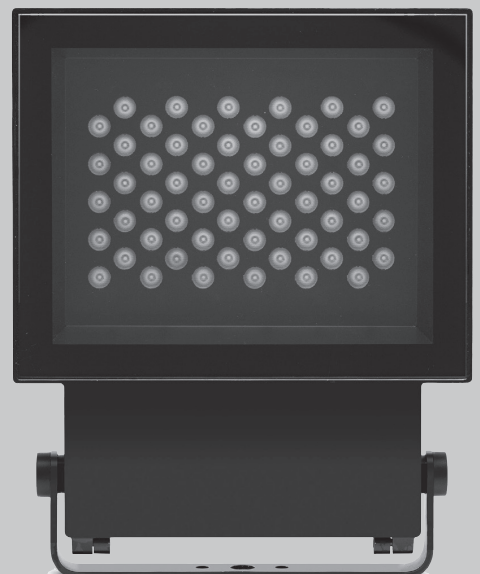
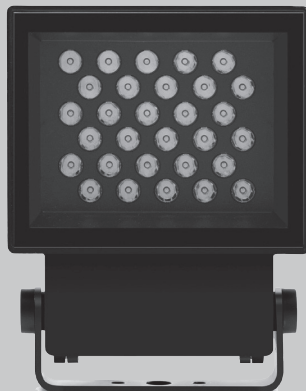



Memorial Church, Berlin, Germany. Luminaire: 49. Light planning: Kardorff Ingenieure Lichtplanung GmbH ©Linus Lintner

Gedächtniskirche, Berlin

Memorial Church, Berlin, Germany

Durch die Scheinwerferserie 49 von SILL erstrahlt die Turmruine der Kaiser-Wilhelm-Gedächtniskirche in Berlin in sanftem Licht und warmweißer Lichtfarbe. Gegenüber der Altanlage konnten die Anzahl der Scheinwerfer halbiert und die Stromkosten reduziert werden. Die präzise Lichtlenkung erlaubt eine stimmungsvolle Illumination mit nach oben abnehmender Intensität. Dadurch bleibt das historische Baudenkmal auch bei Nacht repräsentativ sichtbar und als Mahnmahl für den Frieden erlebbar.

With the SILL 49 projector series, the ruins of the tower of the Kaiser Wilhelm Memorial Church in Berlin are softly illuminated in warm white light. Compared to the old system, the number of floodlights has been halved and the electricity costs reduced. The precise light control allows an atmospheric illumination with decreasing intensity. Thus, the historical monument is visible by night and represents a memorial for peace.

LED-Scheinwerfer zur Akzentuierung im Bereich Architektur und Städtebau
LED-Projector for accent lighting in architecture and urban planning

Stärken Strengths



FLEXIBILITÄT FLEXIBILITY

Aufgrund **drei verschiedener Baugrößen** und einem **kompakten Gehäuse** können Gebäude mit dem jeweils geeigneten Lichtstrom beleuchtet werden
Due to **three different sizes** and a **compact housing**, buildings can be illuminated with the appropriate luminous flux in each case



ZUBEHÖR ACCESSORIES

Ein **umfangreiches Zubehör** ermöglicht das Licht zu modellieren, um individuell auf bauliche Gegebenheiten oder flexibel auf die Beleuchtungsaufgabe eingehen zu können
An **extensive range of accessories** enables the light to be modelled for individual adaptation to architectural conditions or flexible response to the lighting task



LICHTTECHNIKEN LIGHTING TECHNIQUES

Mithilfe von **sechs verschiedenen Lichttechniken** von Narrow Spot bis Flood sind unterschiedliche Beleuchtungsszenarien für den Außenbereich möglich
With the help of **six different lighting technologies** from narrow spot to flood, various lighting scenarios for outdoor areas are possible

SILL

Baugrößen Dimensions

Zubehör Accessories

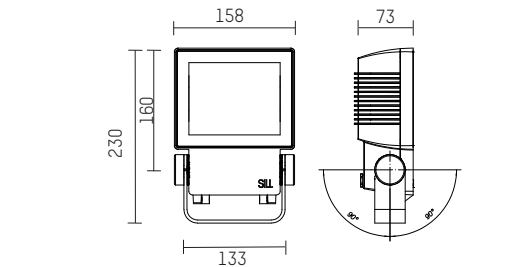

49S

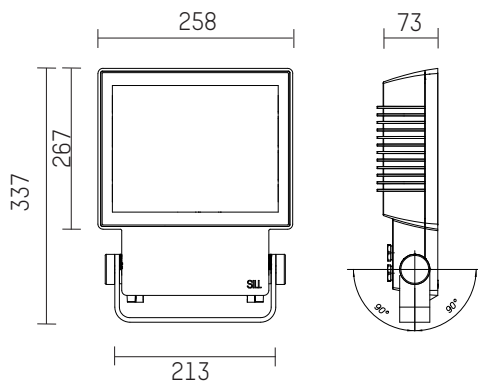

49M

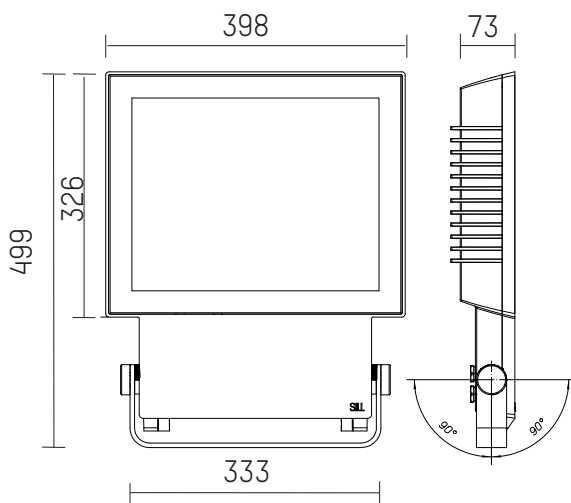

49L

Blenden und Gitter, außen aufsetzbar Guards and screens, externally -mounted



Abblendtore ausstellbar
adjustable screen-doors



Vierseitige Blende
four-sided screen



Dreiseitige Blende
three-sided screen



Blende vertikal
vertical screen



Blende horizontal
horizontal screen



Drahtschutzgitter
wire guard



Wabenraster
honeycomb louver

Gläser und Filter, innen einsetzbar Glasses and filters, internally-mounted



Strukturglas Albarino S
structured glass Albarino S

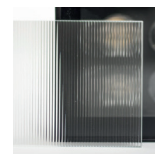

Rillenglas vertikal
grooved glass vertical



Rillenglas horizontal
grooved glass horizontal

SILL

Befestigungen Fixings methods

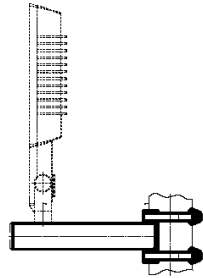
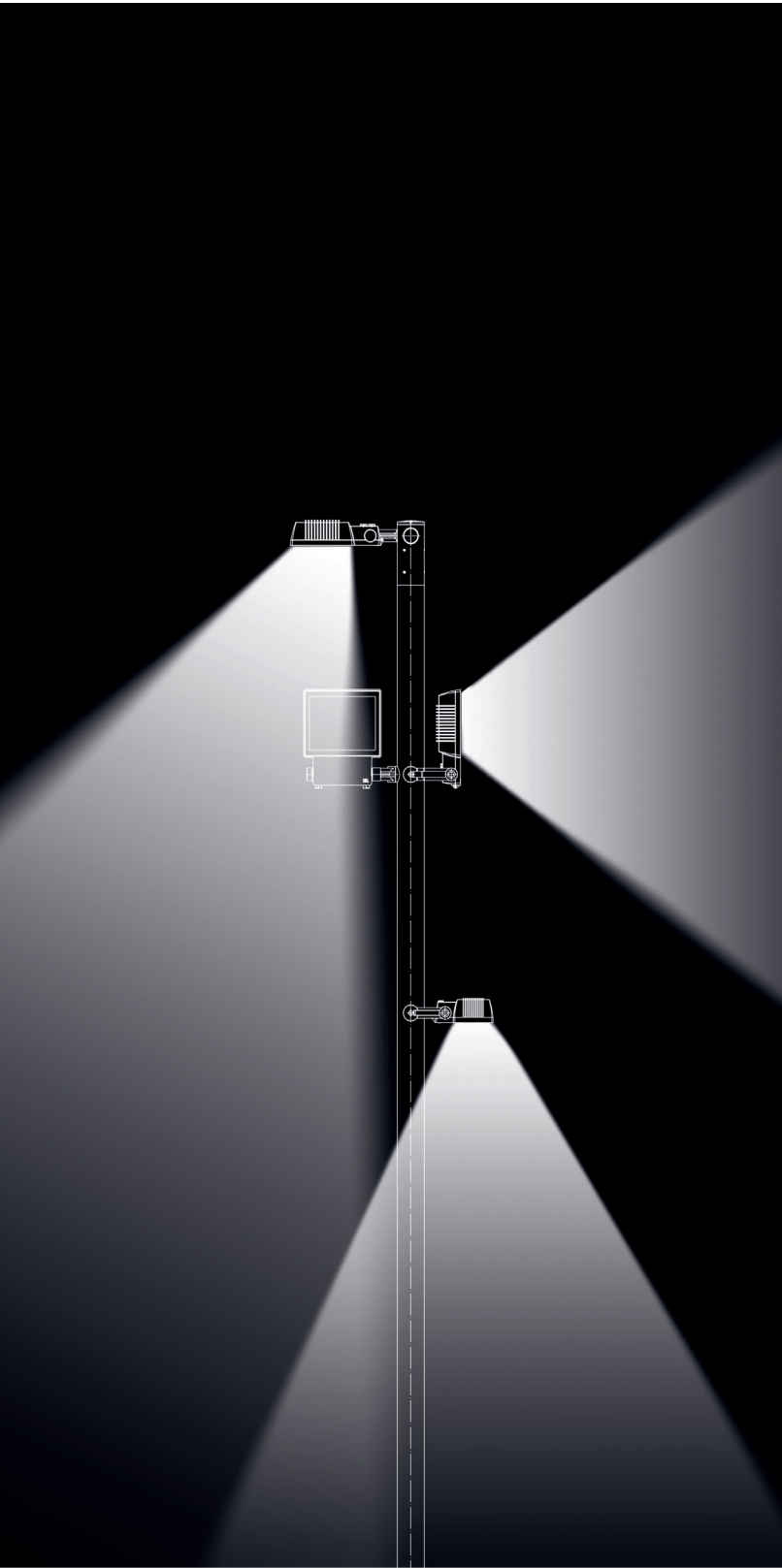

Mastausleger
column mounting bracket

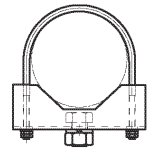

Mastschelle
column clamp

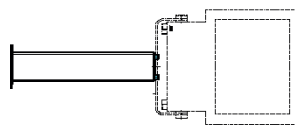

Wandausleger
wall bracket

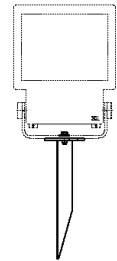

Erdspieß
ground spike

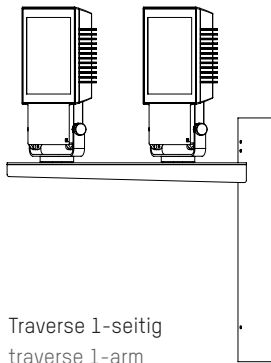

Traverse 1-seitig
traverse 1-arm

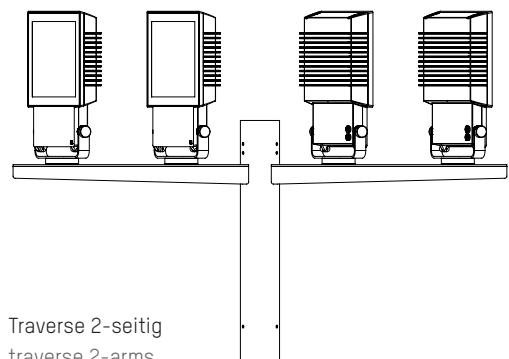

Traverse 2-seitig
traverse 2-arms



Technische Eigenschaften Technical characteristics

Produktgröße product size	49S, 49M, 49L
Leuchtmittel lamp	LED
Farbtemperatur colour temperature	2700 K, 3000 K, 4000 K, 5700 K
Betriebsgerät Typ control gear type	DALI (Amplitudendimmung, flickerfrei) DALI (amplitude dimming, flicker-free)
Betriebsgerät Spannungsbereich operating device voltage range	0/50-60 HZ, 220-240 V
CRI	CRI > 80
Farbabweichung colour deviation	SDCM < 3
Schutzart protection rating	IP65
Schutzklasse protection class	I
LED Lebensdauer LED lifetime	L80 / B10 (50.000h)
Schlagfestigkeit impact resistance	IK09 (49S, 49L), IK08 (49M)
Max. Umgebungstemperatur max. ambient temperature	55°C (49M, 49L), 40°C (49S)
Schwenkbereich pivoting range	± 90° schwenkbar ± 90° tiltable
Befestigungsarten mounting types	Wand-, Boden- oder Mastmontage wall/floor/pole mounting
Farbe colour	schwarz (Standard), silber, weiß black (standard), silver, white
Garantie guarantee	5 Jahre 5 years



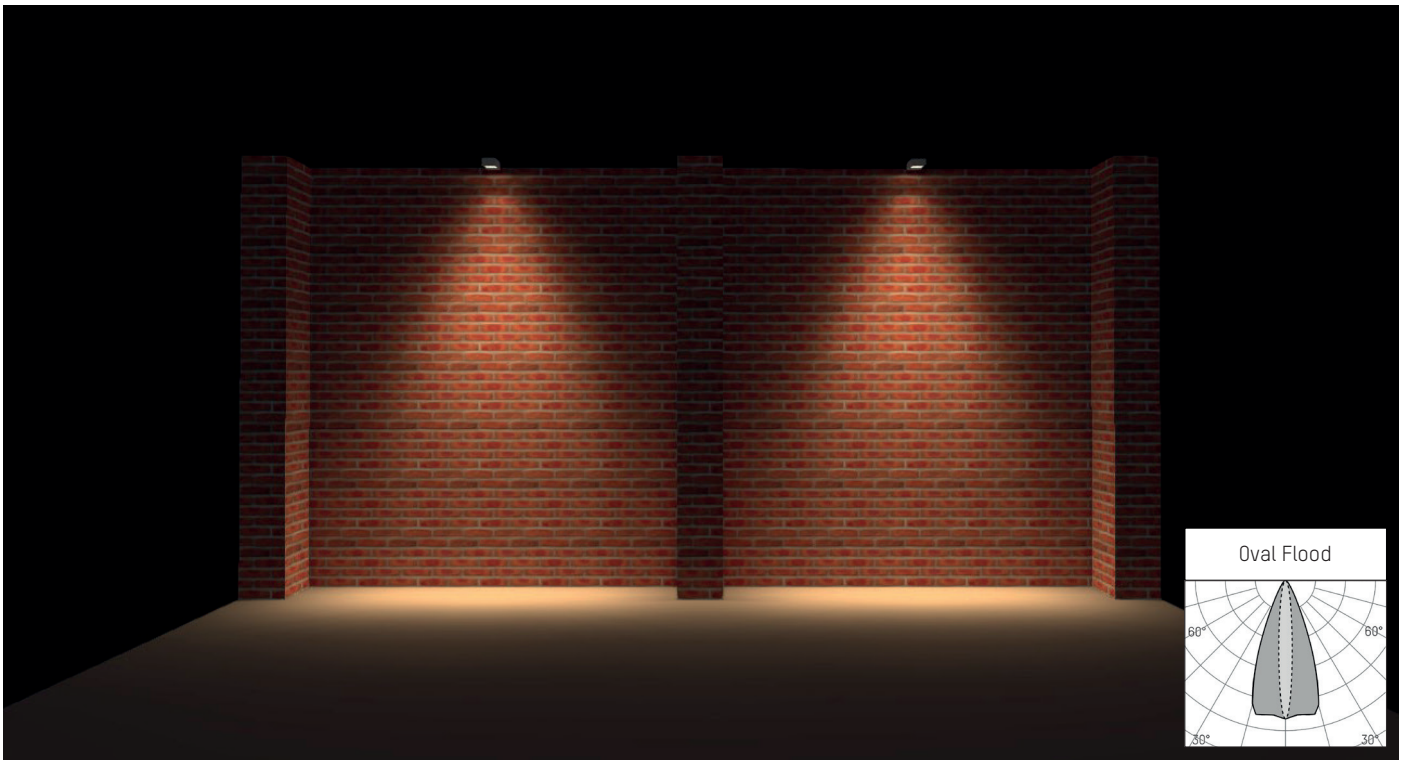

Oval Flood 12° x 40°

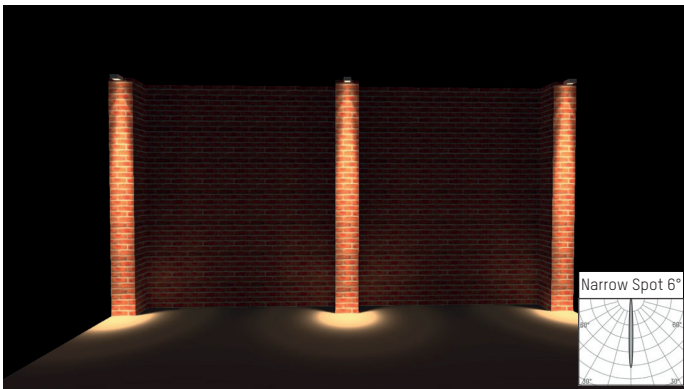

Narrow Spot 6°

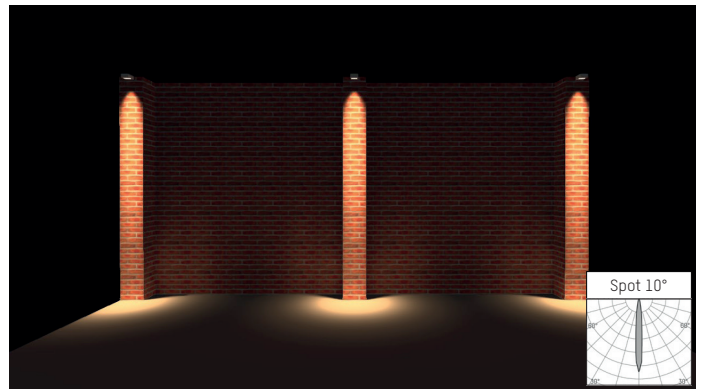

Spot 10°

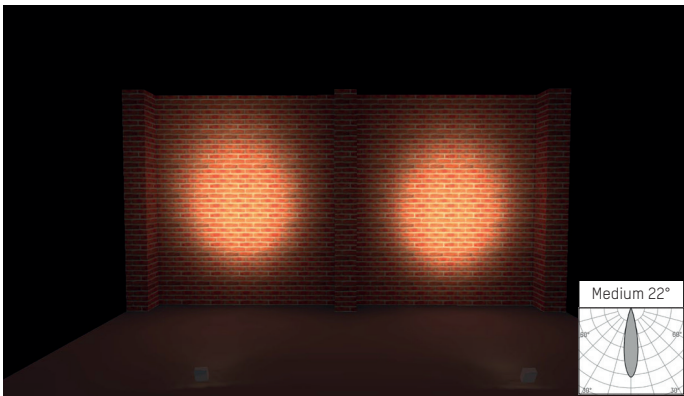

Medium 22°

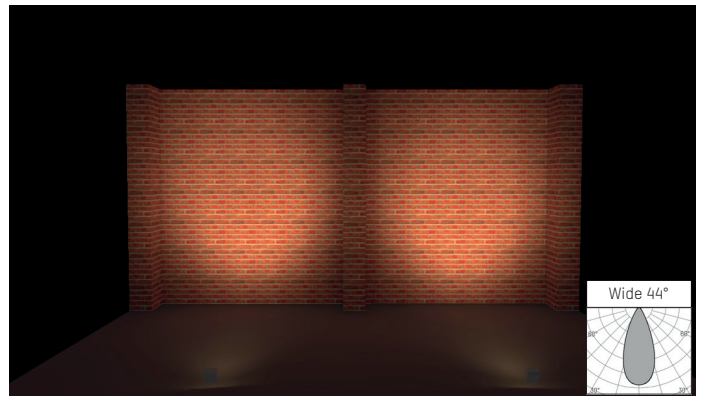

Wide 44°

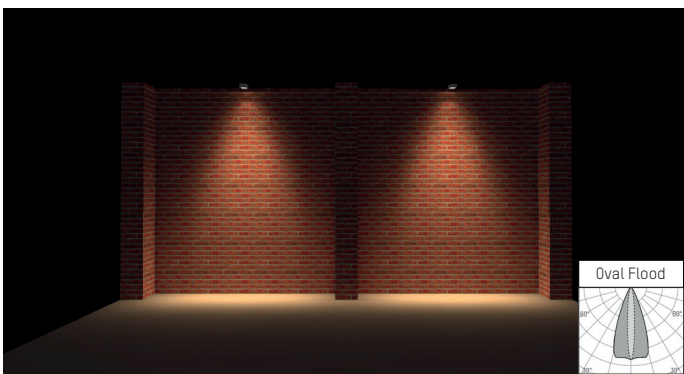

Oval Flood 12° x 40°

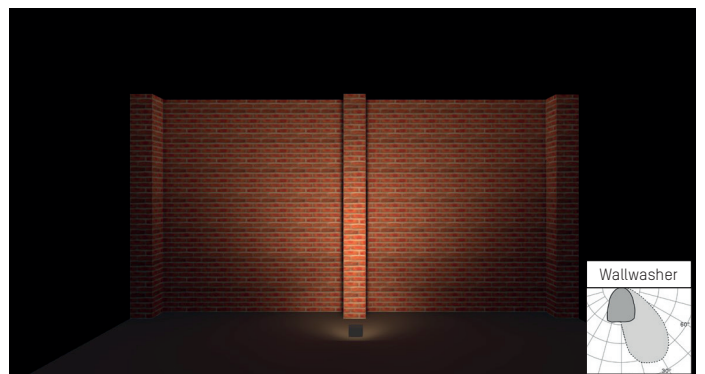

Wallwasher

Sammode, Hoffmeister und Sill haben sich zusammengeschlossen: zu SHS Lighting, dem europäischen Spezialisten für technische Beleuchtung.

Unsere drei Industrieunternehmen in Familienhand zeichnen sich alle durch jahrzehntelanges Know-how, hohe Innovationskraft und Exzellenz aus. Unsere industrielle Expertise ermöglicht es uns, die Relevanz, Leistung, Zuverlässigkeit und Langlebigkeit all unserer Produkte zu garantieren, wobei ein besonderes Augenmerk auf das Design gelegt wird.

Als Designer, Hersteller und Berater setzen wir auf ein kundenorientiertes Ergebnis mit maßgeschneiderten Lösungen.

Wenn sich ein Kunde für eine unserer Lichtlösungen entscheidet, erwirbt er nicht nur eine Leuchte, sondern auch das Fachwissen und den dazugehörigen Service.

Sammode, Hoffmeister and Sill have formed a new alliance: SHS Lighting, the European specialist in technical lighting.

As a family owned business, our three companies share decades of expertise, innovation and excellence. Our industrial expertise sets a benchmark in lighting. It defines our uniquely high standards, allowing us to guarantee the precision, performance, reliability and long-term robustness of all our products, with the utmost flexibility and a particular attention to design.

We are designers, manufacturers and technical advisors. When clients choose one of our products, they get more than a light fixture: they acquire our intelligence and service.

Kontakt
Contact

SHS Lighting
Sammode, Hoffmeister, SILL

Sitz Deutschland
Headquarter Germany
Gewerbering 28-32
58579 Schalksmühle
T +49 (0) 2355 5041 0

mail@hoffmeister.de

Sitz Frankreich
Headquarter France
24, rue des Amandiers
75020 Paris
T +33 (0) 1 43 14 84 90

info@sammode.com
enquiry@sammode.com

sammode.com
studio.sammode.com
hoffmeister.com
sill-lighting.com



@hoffmeister.lighting
@sill.lighting
@sammode.lighting

Irrtümer und technische
Änderungen vorbehalten.
Sill Lighting 06/2021.

Errors and technical
changes excepted.
Sill Lighting 06/2021.



Sammode

HOFFMEISTER

SILL